



LARGE DEBRIS STRAINER



Flo Trend's Large Debris Strainer is designed to be used to strain out large debris during the offloading of vacuum trucks. The unit has 2,380 square inches of strainer basket area and 82 gallons of storage volume above the strainer basket. The vessel is designed to hold up to 30 PSI of pressure without leaking.

The inlet manifold helps distribute the load evenly across the strainer basket. The 30 lb. end covers are hinged with swing bolt and wing nut closures. The strainer baskets are made in two sections which slide out of either end of the strainer vessel for solids removal when the end covers are open. The end of the strainer baskets is hinged and pivots down and out of the way when cleaning debris out of the basket.

SCHEDULE OF OPENINGS

MARK	SIZE	FACING	SERVICE
A	4"	F CAM	INLET
B	4"	M CAM	OUTLET
C	4"	FNPT	VENT
D	1"	FNPT	CLEANOUTS
E	1"	FNPT	FLUSH
F	2"	FNPT	LOCAL INLET

APPROVED BY: _____
 APPROVED AS NOTED: _____
 DISAPPROVED BY: _____
 DATE: _____

EQUIPMENT LIST

ITEM	DESCRIPTION
1	SEPTIC STRAINER
2	SWING BOLT END COVERS
3	SUPPORT LEGS
4	STRAINER BASKET
5	LIFTING OPENINGS
6	4" INLET MANIFOLD CONNECTOR
7	6" MANIFOLD ASSEMBLY
8	4" OUTLET MANIFOLD
9	4" BALL VALVES
10	4" BALL VALVE
11	1" BALL VALVE

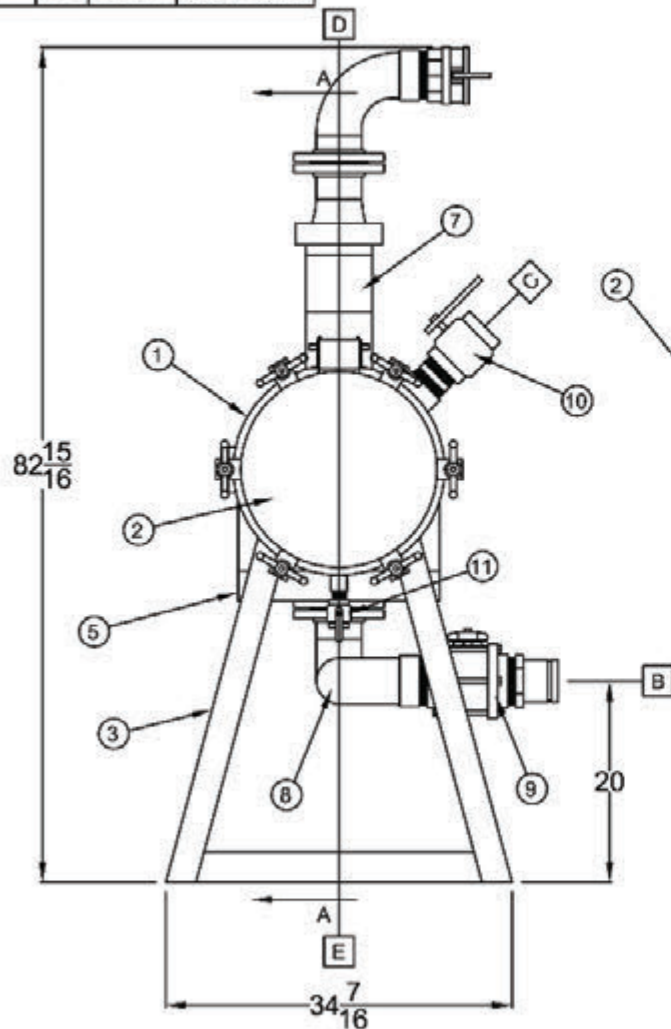

END VIEW

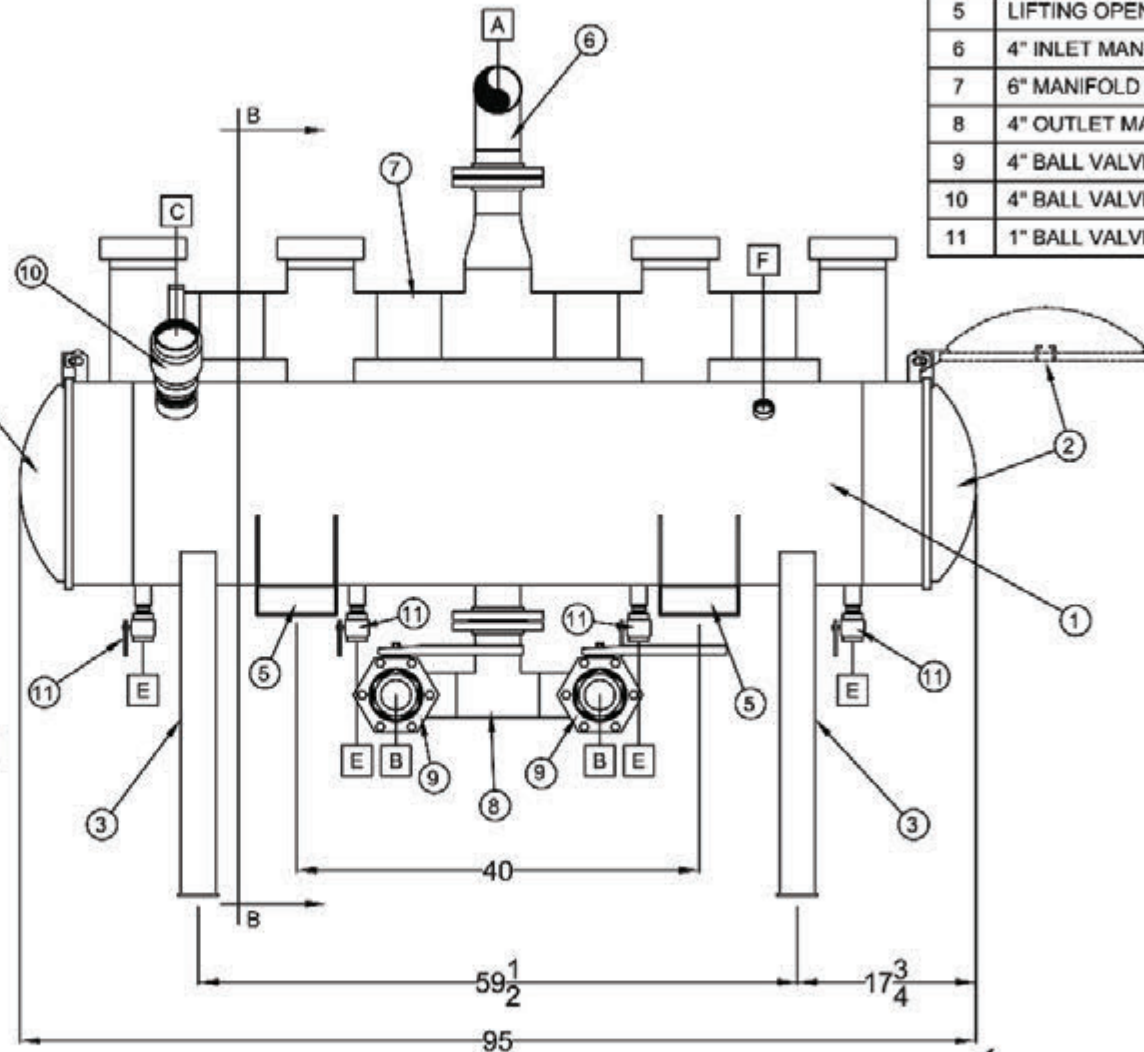

SIDE VIEW

THESE DRAWINGS CONTAIN CONFIDENTIAL, PROPRIETARY INFORMATION. THEY ARE NOT TO BE COPIED, REPRODUCED OR USED IN ANY MANNER THAT WOULD COMPROMISE THE CONFIDENTIALITY OF THE INFORMATION CONTAINED HEREIN. THESE DRAWINGS ARE NOT TO BE USED FOR CONSTRUCTION, FABRICATION OR SPECIFICATION WRITING PURPOSES UNLESS A SPECIFIC CONFIDENTIALITY AGREEMENT AND LICENSING AGREEMENT HAVE FIRST BEEN ENTERED INTO WITH FLO TREND SYSTEMS, INC. OF HOUSTON, TEXAS. FAILURE TO OBSERVE THE CONDITIONS OF THIS NOTICE WILL RESULT IN PROSECUTION AS ALLOWED UNDER THE LAWS OF THE STATE OF TEXAS, U.S.A. OR THOSE OF ANY OTHER APPROPRIATE JURISDICTION AS FLO TREND SYSTEMS, INC.

FLO TREND SYSTEMS, INC.
 707 LINDAWAY SOULS HOUSTON, TEXAS 77018
 DRAWN BY: JM

QMS: NONE	APPROVED BY: _____	REVISED: _____
DATE: 09-01-11	DESCRIPTION: GENERAL ARRANGEMENT	DATE: 12-08-11
TITLE: FTS SEPTIC STRAINER II		DRAWING NUMBER: 11S0314-001